



# INNOTECH VL-10-200



[mm]

1.)

2.)

3.)

4.)

5.)

nur / only  
EAP-STABIL  
AIO-SZH-10  
~~AIO-EB-...~~  
~~AIO-EDLE-...~~

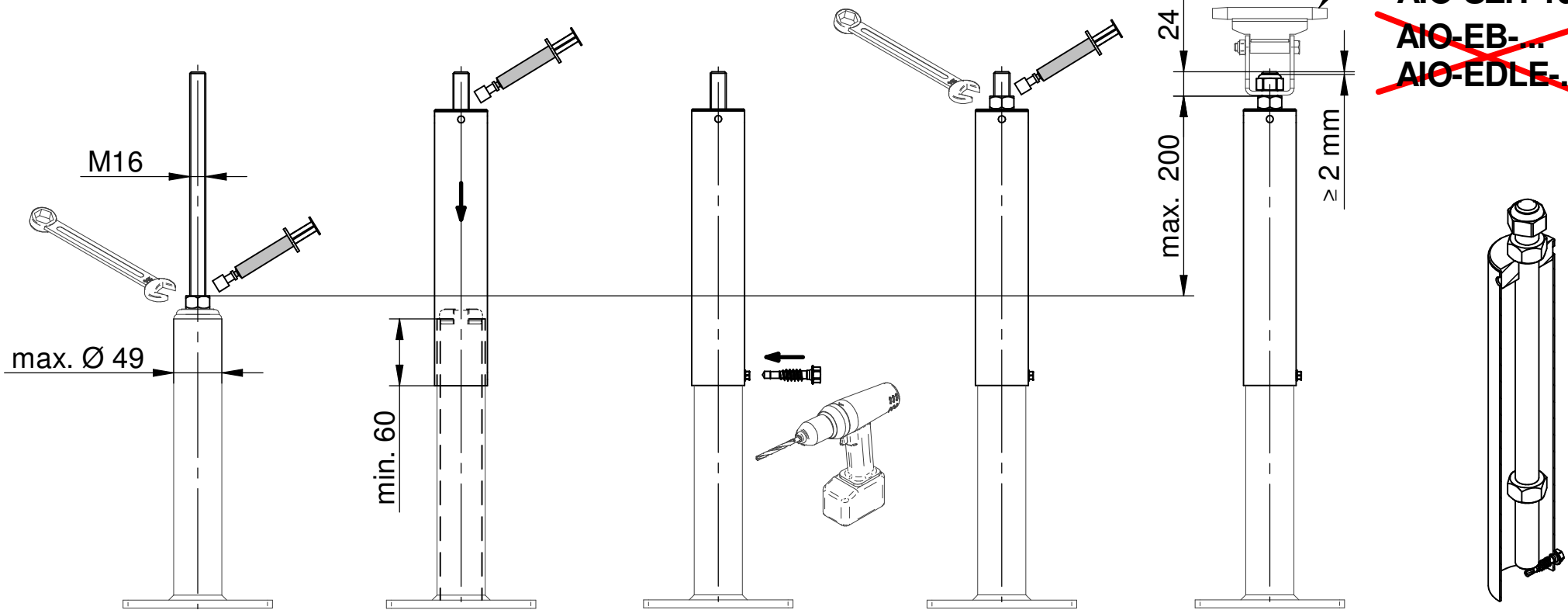

				Datum	Name	Projekt / Benennung			
				Bearb.	12.03.2012 Auinger S.	<b>VL-10-200</b>			
				Gepr.	31.10.2018 Leeb R.		<b>Montageanleitung VL-10-200</b>		
E	EAP-STABIL + AIO-SZH	31.10.2018	Leeb	Norm		Zeichnungsnummer <b>08-10-200-A2-Montageanleitung</b>		Rev.	Blatt
D	DE-Texte	02.02.2016	Leeb	Status	Freigegeben		<b>E</b>	<b>1/1</b>	
C	Design angepasst	12.03.2012	Auing	Arbeitsschutz GmbH A-4656 Kirchham, Laizing 10 www.innotech.at +43 (0) 7619 / 22122					
B	Dokument erstellt	21.06.2013	Tremi						
A	Dokument erstellt	27.04.2011	Tremi						
Zust.	Änderung	Datum	Na.			Ersatz für	Format	A4	Solid Edge