

1 2 3 4

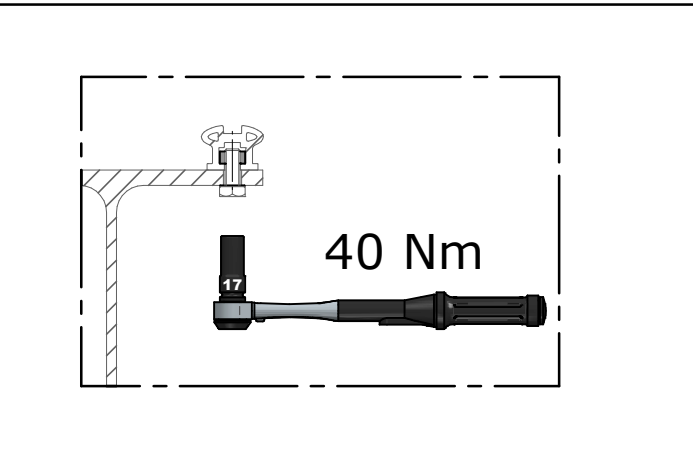
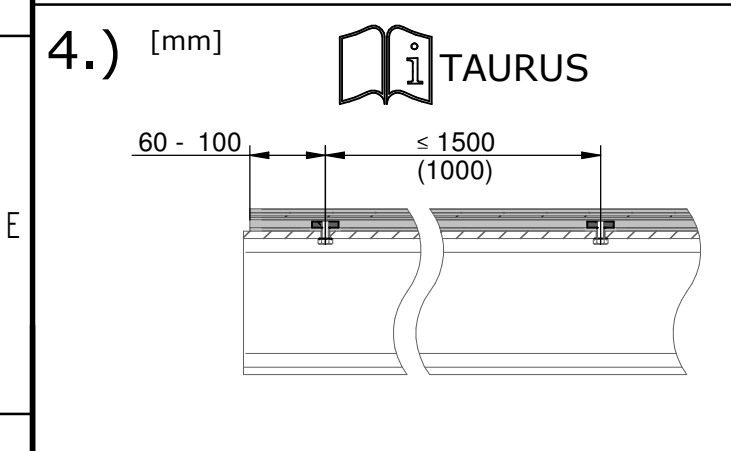
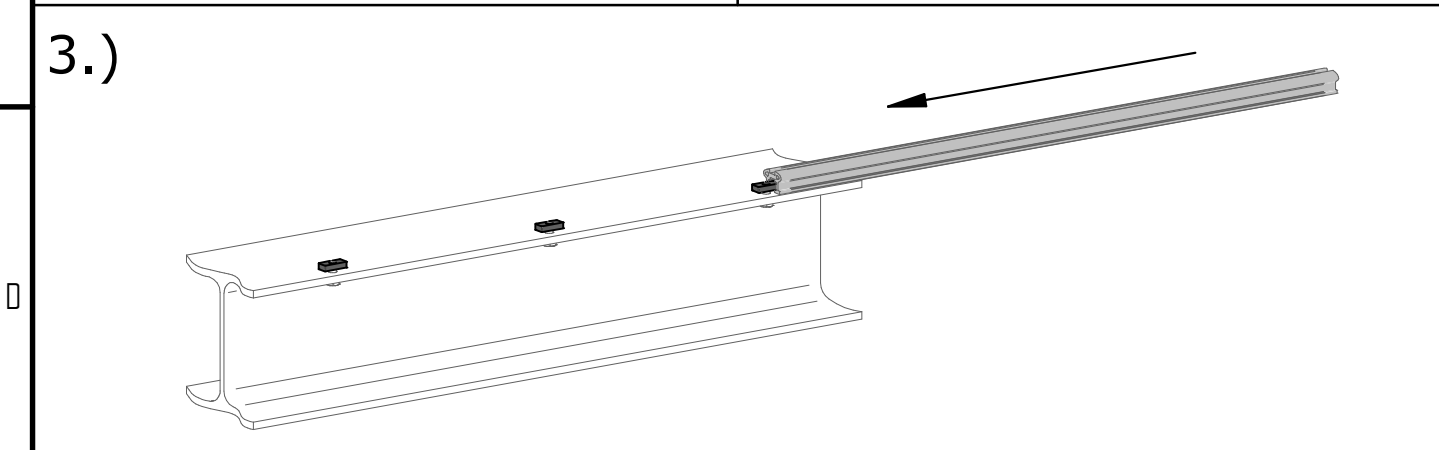
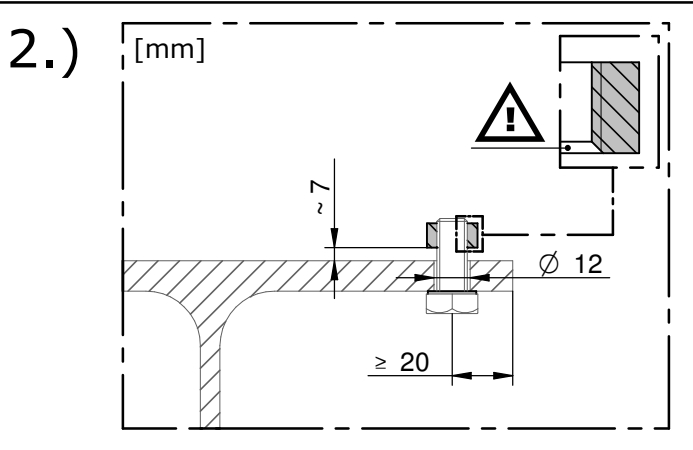
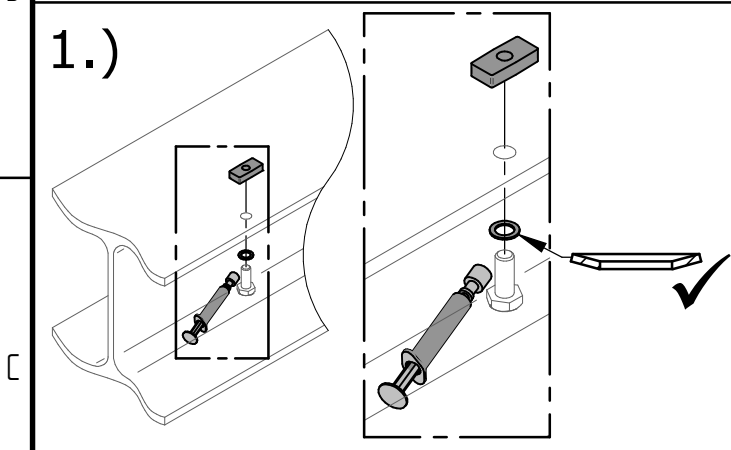
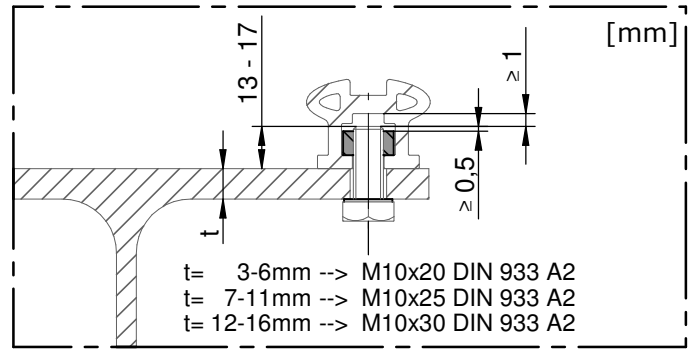
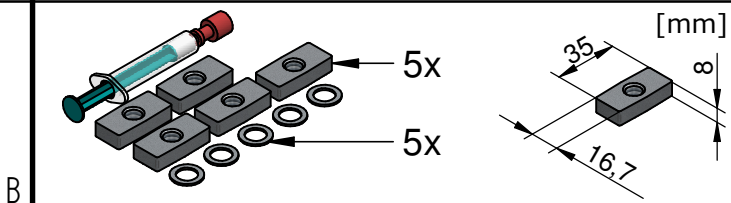
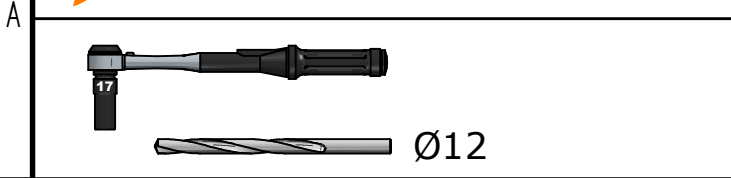

				Datum	Name
				Bearb. 02.02.2012	Leeb R.
F	Abstände	14.08.2019	Leeb	Gepr. 14.08.2019	Leeb R.
E	DE-Texte	29.01.2016	Leeb	Norm	
D	Kontur geändert!	26.04.2013	Leeb	Status	Freigegeben
C	Abmessungen	27.06.2012	Leeb	Arbeitsschutz GmbH A-4656 Kirchham, Laizing 10 www.innotech.at +43 (0) 7619 / 22122	
B	Schmiermittel neu	08.05.2012	Leeb		
A	Dokument erstellt	02.02.2012	Leeb		
Zust.	Änderung	Datum	Na.		

Projekt / Benennung		
Montageanleitung		
TAURUS-BEF-12		
Zeichnungsnummer	Rev.	Blatt
14-06-12-Montageanleitung	F	1/1
Ersatz für	Format A4	Solid Edge